

Air Compressor Manual



For questions concerning this air compressor,
please call 866-869-3114

TABLE OF CONTENTS

PAGE

1	Safety Guidelines - Definitions Before Using the Air Compressor
2	When Installing or Moving the Compressor Before Each Use
3	Follow Safety Precautions for Electrical Connection Plan Ahead to Protect Your Eyes, Hands, Face & Ears When Operating
4	Spraying Precautions Perform These Maintenance Operations
5	Typical Compressor Installation Glossary
6-9	Wiring
10-11	Starting the Compressor
12	QP Compressor
13-14	Troubleshooting
15	Pump and Tank Specs
16	Tank Warning
17	Parts Reference
18	Single Stage and Contractor
19	Two Stage
20	Gas Drive and Duplex
21	QP
22	Electric Two Stage and Duplex
23-24	PAT24 and PAT38
25	T29S
26	B5900
27	T39
28-29	C1
30-31	C2
	Back Warranty Statement

Please read and save these instructions. Read through this owner's manual carefully before using product. Protect yourself and others by observing all safety information, warnings, and cautions. Failure to comply with instructions could result in personal injury and/or damage to product or property. Please retain instructions for future reference.



AIR COMPRESSOR

FOR CUSTOMER SERVICE

Technical Question?

CALL 1-866-869-3114

UNPACKING

After unpacking unit, inspect carefully for any damage that may have occurred during transit. Check for loose, missing, or damaged parts. If any damage is observed, a shipping damage claim must be filed with carrier. Do not use the OEMTOOLS™ Compressor if broken, bent, cracked or damaged parts (including labels) are noted. Any Compressor that appears damaged in any way, operates abnormally or is missing parts should be removed from service immediately. If you suspect that the Compressor was subjected to shock load (a load that was dropped suddenly, unexpectedly, etc.) immediately discontinue use until it has been checked by a factory authorized service center.



⚠ WARNING

The following safety information is provided as a guideline to help you operate your Compressor under the safest possible conditions. Any tool or piece of equipment can be potentially dangerous to use when safety or safe handling instructions are not known or not followed. The following safety instructions are to provide the user with the information necessary for safe use and operation. Please read and retain these instructions for the continued safe use of your service system. Failure to follow instructions listed below may result in serious injury. In addition, make certain that anyone who uses the equipment understands and follows these safety instructions as well.

Explanation of Safety Signal Words

⚠ DANGER: Means if safety information is not followed someone will be seriously injured or killed.

⚠ WARNING: Indicates a potentially hazardous situation which, if not avoided, could result in death or serious injury.

⚠ CAUTION: Indicates a potentially hazardous situation which, if not avoided, may result in minor or moderate injury.

CAUTION: Used without the safety alert symbol indicates a potentially hazardous situation which, if not avoided, may result in property damage.

NOTES: Provide clarity and helpful information.

⚠ WARNING: Pursuant to California Proposition 65, this product contains chemicals known to the state of California to cause cancer and birth defects or other reproductive harm. Wash hands after handling.



AIR COMPRESSOR

IMPORTANT SAFETY INSTRUCTIONS

Save these instructions.

Improper operation or maintenance of this product could result in serious injury and property damage. Read and understand all warnings and operation instructions before using this compressor.

1. Only persons familiar with these rules of safe operation should use the air compressor.
2. Read the instruction manual carefully before attempting to assemble, disassemble or operate your system. Be thoroughly familiar with the controls and the proper use of the equipment.
3. Review and understand all safety instructions and operating procedures in this manual.
4. Review the maintenance methods for this compressor (See "Maintaining Your Compressor" section).
5. Inspect your work area. Keep work area clean and well lit.
6. Cluttered areas and benches invite accidents. Floors must not be slippery from wax or dust.
7. Operate compressor in a well-ventilated area free from flammable liquids and vapors.
8. Operate compressor in a ventilated area so that compressor may be properly cooled and the surrounding air temperature will not be more than 100°F.
9. Never use a compressor in a wet environment.
10. Protect material lines and air lines from damage or puncture. Keep hose and wires away from sharp objects, chemical spills, oil, solvents and wet floors.
11. A minimum clearance of 18 inches between the compressor and a wall is required because objects could obstruct airflow.
12. The compressor should be located where it can be directly wired to a circuit breaker. The compressor should be wired by a qualified electrician.
13. Never store flammable liquids or gases in the vicinity of an operating compressor.
14. DO NOT locate the compressor air inlet near steam, paint spray, sandblasting areas or any other source of contamination. The debris could damage the motor and pump.
15. Wear safety glasses (meeting ANSI Z87.1 or in Canada CSA Z94.3-99) and use hearing protection when operating the unit. Everyday glasses are not safety glasses.
16. Wear shoes to prevent shock hazards.
17. Tie back long hair.

WARNING

18. Keep fingers away from running compressor. Fast moving and hot parts may cause injury and/or burns.

WARNING

19. Be careful when touching the exterior of compressor, pump, motor and air lines; they may become hot enough to cause injury.

WARNING

20. Never operate the compressor without a belt guard. The compressor can start automatically without warning. Personal injury or property damage could occur from contact with moving parts.

CAUTION

21. The compressor may be hot even if the unit is stopped.

WARNING

22. Use of a mask or respirator per chemical manufacturers' instructions may be necessary if there is a chance of inhaling toxic fumes. Read mask and respirator instructions carefully. Consult a safety expert if you are not sure about the use of certain masks or respirators.

BEFORE USING THE AIR COMPRESSOR

Air compressors are utilized in a variety of air system applications. Because air compressors and other components (hoses, connectors, air tools, spray guns, etc.) make up a high pressure pumping system, the following safety precautions should be observed at all times.

INSPECT YOUR COMPRESSOR

1. To reduce the risk of injury from accidental starting, turn switch off and disconnect the power before checking it.
2. If any part is missing, bent or broken in any way, or any electrical part does not work properly, keep the compressor off and disconnected.
3. Check hoses for weak or worn condition before each use, making certain all connections are secure. DO NOT use if defect is found.

WARNING

DO NOT operate compressor if damaged during shipping, handling or use. Damage may result in bursting and cause injury or property damage.

WARNING

This compressor is not designed for and should not be used in breathing air applications.

WHEN INSTALLING OR MOVING THE COMPRESSOR

This compressor is extremely top heavy. The compressor must be bolted to the floor with vibration pads before operating to prevent equipment damage, injury or death. DO NOT tighten bolts completely as this may cause stress to the tank welds.



AIR COMPRESSOR

⚠ WARNING

DO NOT secure compressor with toggle bolts into drywall. Drywall sheeting or plaster will not support the weight of the compressor.

Always shut off gas valve before moving gas drive compressors.

⚠ WARNING

Never use plastic (PVC) pipe for compressed air. Serious injury or death could result.

⚠ CAUTION

Never use the shipping skid for mounting the compressor.

⚠ NOTICE

Electric Compressors are not suitable for outdoor installation.

⚠ NOTICE

Gasoline Compressors must be operated outdoors, sheltered from the weather.

⚠ WARNING

Never install a shut off valve between the compressor pump and tank. Personal injury and/or equipment damage could occur.

FOLLOW THE SAFETY PRECAUTIONS FOR ELECTRICAL CONNECTIONS

1. Follow all local electrical and safety codes, as well as the National Electric Code (NEC) and the Occupational Safety and Health Act (OSHA).
2. Wiring and fuses should follow electrical codes, current capacity and be properly grounded.
3. Protect wires from contact with sharp objects.

⚠ CAUTION

All electrical connections should be made by a qualified electrician.

WHEN OPERATING

1. DO NOT exceed the pressure rating of any component of the system.
2. Release pressure within the system slowly to prevent flying dust and debris.
3. If the equipment starts to abnormally vibrate, STOP the compressor immediately and check for the cause.

⚠ WARNING

Never change the safety valve or pressure switch settings. Keep safety valve free from paint and other accumulations. See compressor specification decal for maximum operating pressure. DO NOT operate with the pressure switch set higher than the maximum operating pressure.

SPRAYING PRECAUTIONS

⚠ WARNING

Never point a spray gun at yourself or any other person or animal. Accidental discharge may result in serious injury.

REDUCE THE RISK OF DANGEROUS ENVIRONMENT

⚠ WARNING

Extreme caution should be taken when spraying flammable liquids as the spark from a motor or pressure switch may cause a fire or explosion. Ample ventilation must be provided.

⚠ WARNING

Spray in a well-ventilated area to keep fumes from collecting and causing serious injury and fire hazards.

1. DO NOT spray in the vicinity of open flames or other places where a spark can cause ignition.
2. DO NOT smoke when spraying paint, insecticides, or other flammable substances.

BE INFORMED ABOUT THE MATERIALS YOU USE

1. When spraying with solvents or toxic chemicals, follow the instructions provided by the chemical manufacturer. Consult a safety expert if unsure about the use of masks or respirators.
2. If the material you intend to spray contains trichloroethane and methylene chloride, do not use accessories that contain aluminum or galvanized materials, as these chemicals can react with galvanized components causing corrosion and weakening equipment. Use stainless steel accessories.

PERFORM THESE MAINTENANCE OPERATIONS

1. Do regular maintenance; keep all nuts, bolts, and screws tight, to be sure equipment is in safe working condition.
2. Inspect tank yearly for rust, pin holes or any other imperfections that could cause it to become unsafe.

⚠ WARNING

NEVER attempt to repair or modify a tank! Welding, drilling or any other modification will weaken the tank resulting in damage from rupture or explosion. Always replace worn, cracked or damaged tanks.

3. Clean electrical equipment with an approved cleaning agent, such as a dry, non-flammable cleaning solvent.
4. Drain tanks of moisture after each day's use. If unit will not be used for awhile, it is best to leave the drain cock open until such time as it is to be used. This will allow moisture to completely drain out and help prevent corrosion of inside of tank.



AIR COMPRESSOR

- Always disconnect from power source before working on or near a motor, or its connected load. If power disconnect point is out of sight, secure it in the "OFF" position and tag it to prevent unexpected application of power.

⚠ WARNING

Disconnect power and depressurize system before servicing air compressor. Slightly open drain cock after shutting off compressor.

DAILY

Check oil level at sight glass. Oil level should be 1/2 to slightly higher in the oil sight glass.

Drain moisture from tank.

Verify the pressure switch unloader is working by listening for a brief hissing sound when the compressor shuts off.

Visually check the compressor for loose parts, excessive noise or vibration. Tighten any necessary part.

MONTHLY

(Make sure the main power is off.) Check the belts for tension. Belts should not move up and down when the compressor runs and when stopped, should not have more than 1/2 in of play when depressed. Be careful not to over tighten belts during adjustment.

Remove and check air filter, replace if necessary.

Change oil every 3 months or 300 hours. A compressor grade 30 Wt. non-detergent oil should be used. 40 Wt. non-detergent for single stage.

TYPICAL COMPRESSOR INSTALLATION

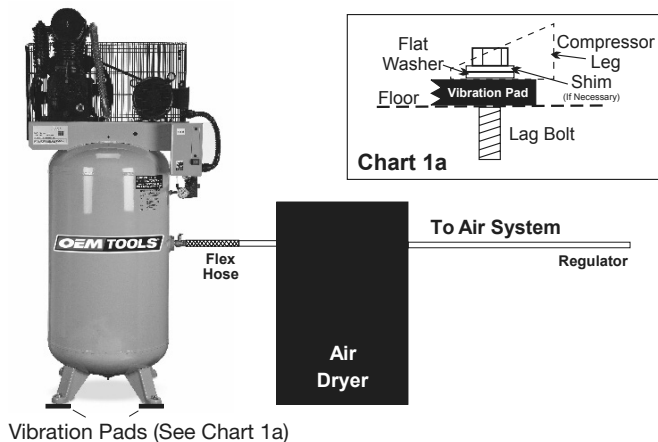

GLOSSARY OF TERMS

AIR FILTER - Porous element contained within a metal or plastic housing attached to the compressor cylinder head which removes impurity from the intake air of the compressor.

AIR TANK - Cylindrical component which contains the compressed air.

CHECK VALVE - Device which prevents compressed air from flowing back from the air tank to the compressor pump.

ELECTRIC MOTOR - Device which provides the rotational force necessary to operate the compressor pump.

PRESSURE GAUGE - Device which shows the tank or regulated pressure of the compressed air.

PRESSURE SWITCH - Device which automatically controls the on/off cycling of the compressor. It stops the compressor when the cut-off pressure in the tank is reached and starts the compressor when the air pressure drops below the cut-in pressure.

PSI (POUNDS PER SQUARE INCH) - Measurement of the pressure exerted by the force of air. The actual PSI is measured by a pressure gauge on the compressor.

PUMP - Device which produces the compressed air with a reciprocating piston contained within a cylinder.

SAFETY VALVE - Device which prevents air pressure in the air tank from rising over a predetermined limit.

THERMAL OVERLOAD SWITCH - Device, integrated into the electric motor winding, which automatically "shuts off" the compressor if the temperature of the electric motor exceeds a predetermined limit.

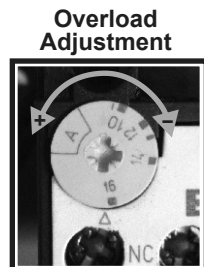



AIR COMPRESSOR

WIRING

⚠ WARNING

ALL ELECTRICAL WIRING SHOULD BE DONE BY A QUALIFIED ELECTRICIAN

GENERAL INFORMATION

Adequate wiring and motor protection should be provided for all stationary compressors. Wiring used for other machinery should not be used. A qualified electrician familiar with local electrical codes in your area should be used. Size supply wiring per NEC (National Electric Code) requirements.

⚠ WARNING

To reduce the risk of electrical hazards, fire hazards or damage to the compressor, use proper circuit protection. Your compressor is wired at the factory for operation using the voltage shown. Connect the compressor to a power source with the correct breaker size.

⚠ CAUTION

Overheating, short circuiting and fire damage will result from inadequate wiring.

⚠ WARNING

Electrical connections must be properly grounded. Ground connections should be connected at the grounding screw. ⚡

DO NOT MAKE CONNECTIONS AT THE PRESSURE SWITCH (UNITS WITH MAGNETIC STARTERS)

SINGLE PHASE

Incoming power should be connected to L1 and L2 at the top of the magnetic starter

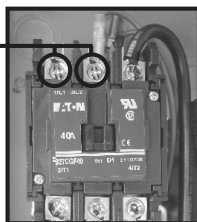

THREE PHASE

Incoming power should be connected to L1, L2 and L3 at the top of the magnetic starter

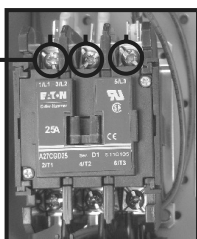

DUPLEX WIRING

(INSIDE CONTROLLER ON THE BOTTOM)

SINGLE PHASE
THREE PHASE

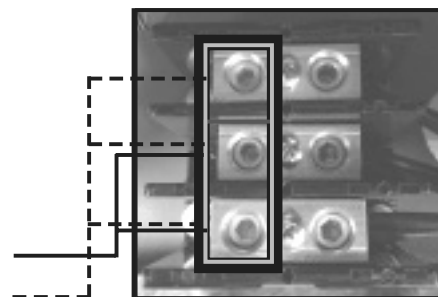

FOR MODELS WITHOUT MAGNETIC STARTER

Incoming power should be connected to the post marked (Line)

⚠ WARNING

DO NOT make connections on prewired posts marked (Motor)

⚠ WARNING

Electrical connections must be properly grounded. Ground connections should be connected at the grounding screw. ⚡

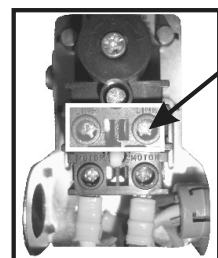



AIR COMPRESSOR

WIRING

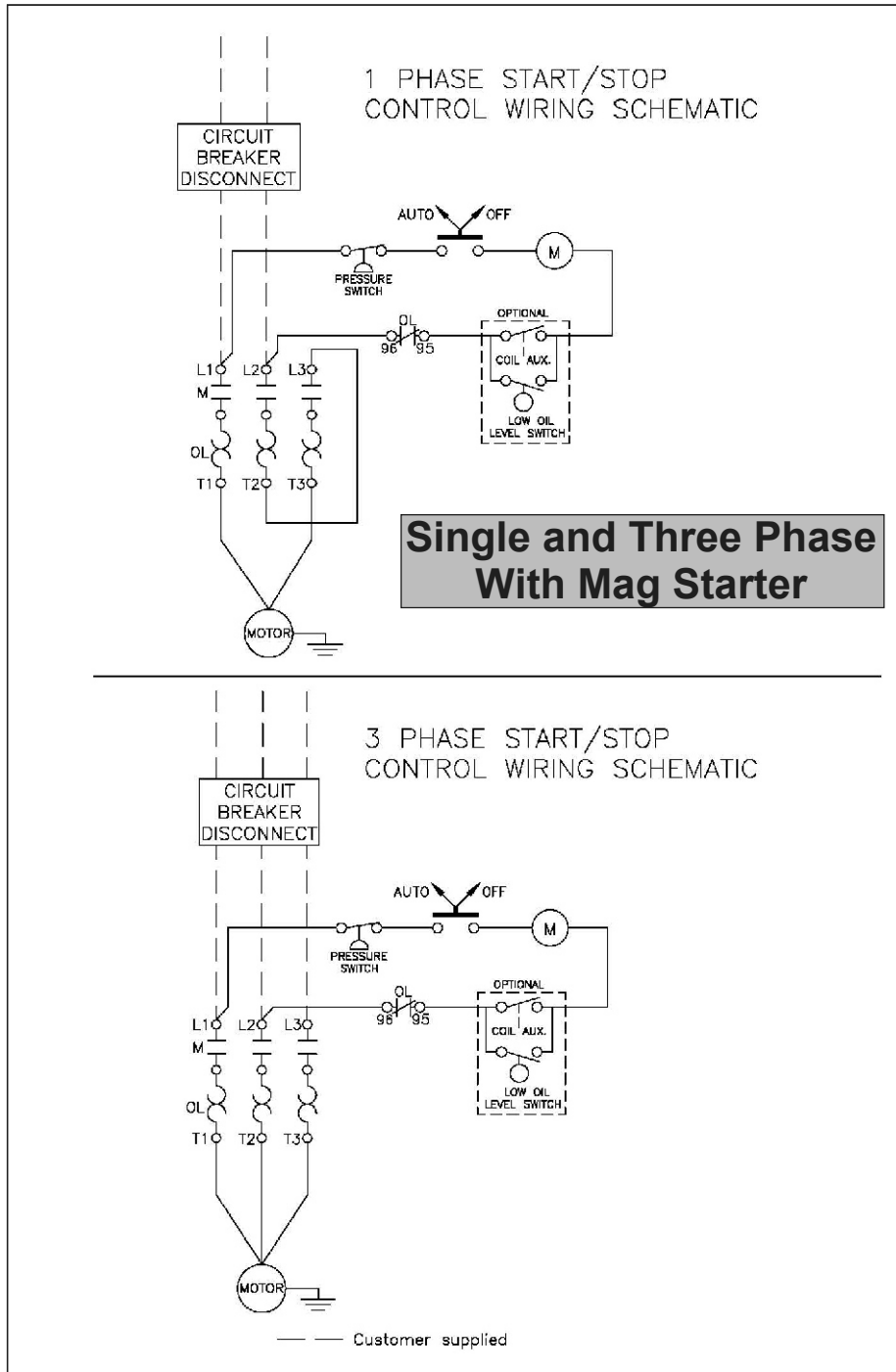



AIR COMPRESSOR

WIRING

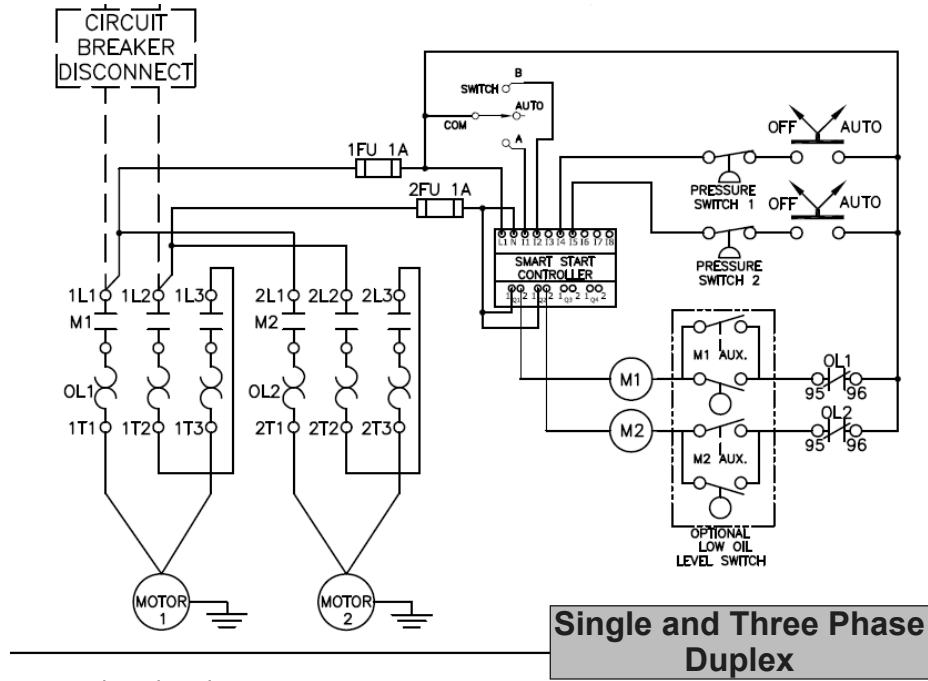

Single and Three Phase Duplex

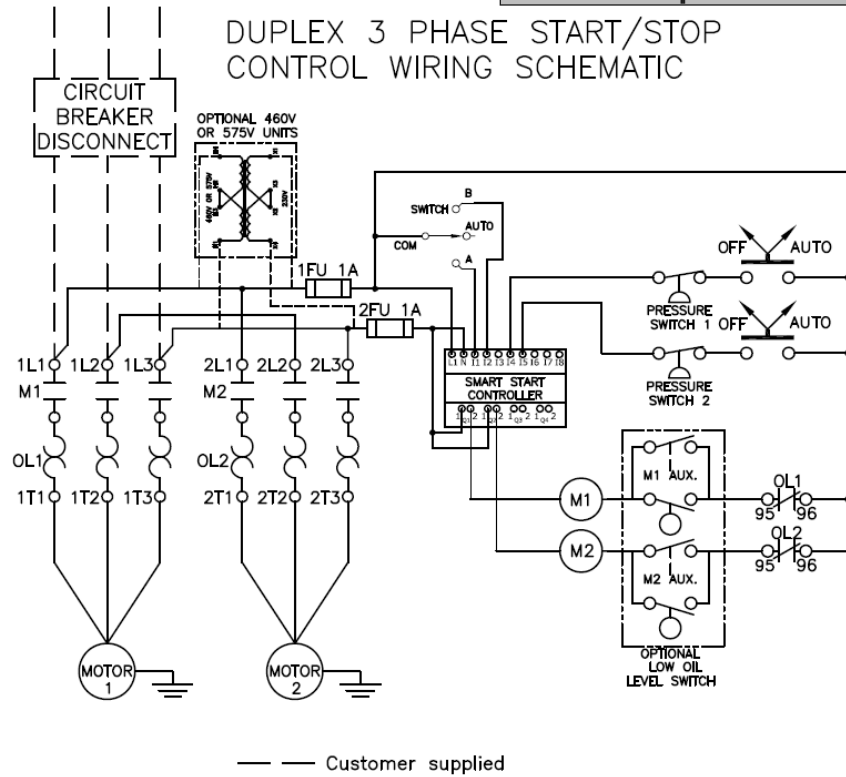



AIR COMPRESSOR

WIRING

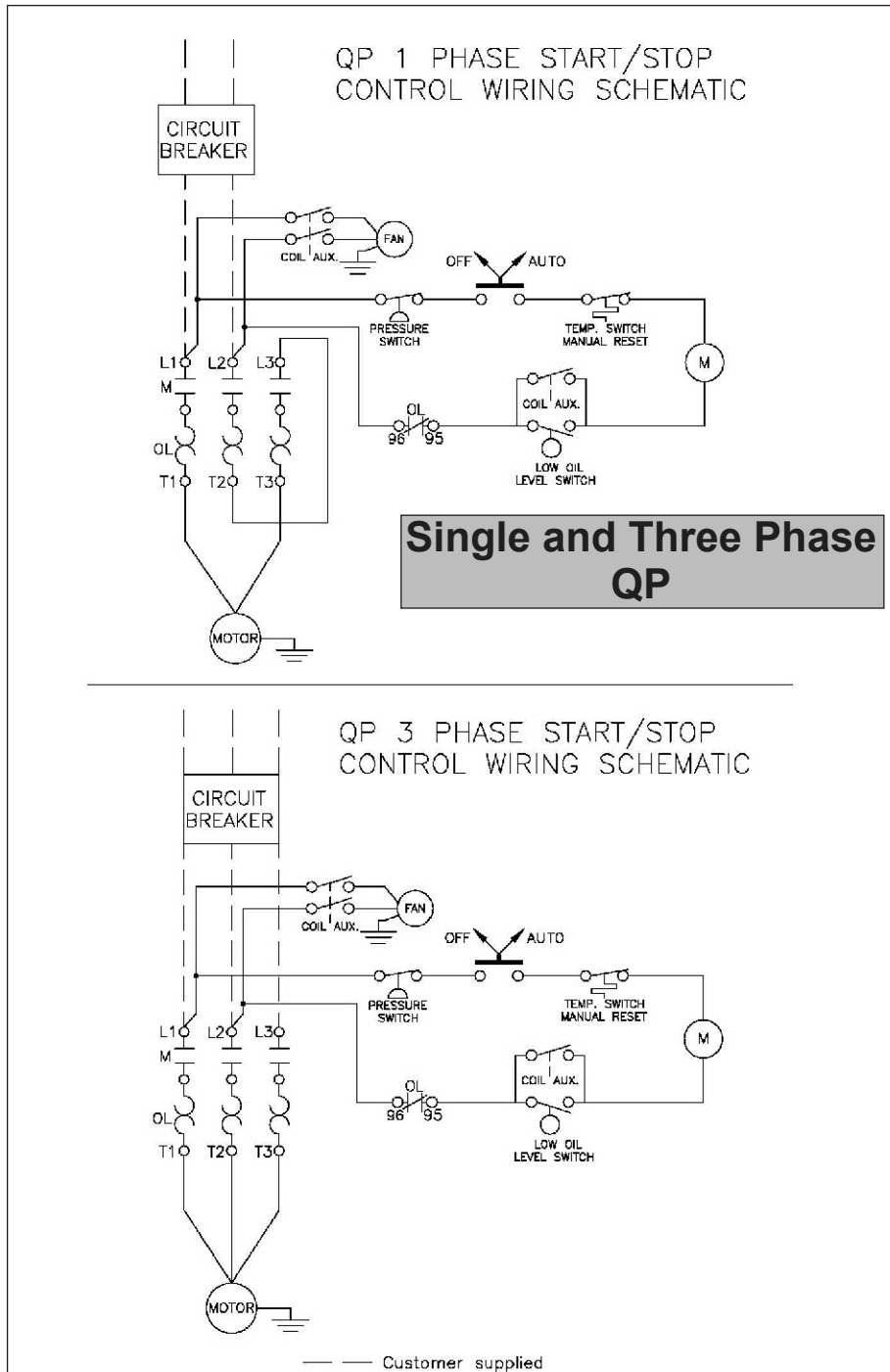



AIR COMPRESSOR

STARTING THE COMPRESSOR

Prior to actually running the compressor, check the following items:

Crankcase oil - Make sure the sight glass shows 1/2 full or slightly above.

Make sure all rags, tools, oil, etc. are away from the unit.

Open the air system to free it of any pressure.

Switch the compressor on for a few revolutions to make sure the rotation is correct. Correct rotation is clockwise when facing the sight glass on the pump.

Operate the compressor for a few minutes unloaded (air system open) then allow the compressor to pump up. Make sure the electrical pressure switch properly switches off the compressor according to the setting desired. 175 for Two Stage.

(135 PSI - Single Stage or 165 PSI - RCP-561VNS)

⚠ CAUTION

Make sure the pressure in the tank does not exceed its rating. Single Stage units - 135 PSI Two Stage units at a maximum of 175 PSI.

(165 for Model 8090255525)

If the pressure gauge indicates a pressure that is higher than these maximum pressures, shut off compressor immediately and call your distributor.

(DUPLEX MODELS)

ALTERNATING RUNNING PROCEDURE

Initial power to the controller takes about 5 seconds to power up and run Motor A will start and then Motor B after a 10 second delay

Both motors will run until unit reaches cutoff pressure (175 PSI)

Each time the unit starts after initial start, the "Lead" motor will alternate

If the unit runs for more than 5 minutes, the second Motor will come on and run until the unit reaches cutoff pressure

The second motor will also come on if the air demand is higher than one pump/motor can produce and the pressure drops to around 135 PSI (10 sec. delay)

A OR B RUNNING PROCEDURE

By selecting A or B on the switch, either Pump/Motor A or Pump/Motor B will operate independently, as a simplex compressor.

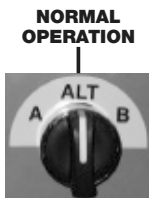

(GAS DRIVE MODELS)

PLEASE REFER TO YOUR ENGINE OPERATION MANUAL FOR PROPER STARTING INSTRUCTIONS.

GASOLINE DRIVEN COMPRESSORS ARE EQUIPPED WITH A COLD START VALVE FOR LOADLESS STARTS.

NOTE: IN SOME INSTANCES, IT STILL MAY BE NECESSARY TO LIFT THE TOGGLE ON THE UNLOADER/PILOT VALVE TO RELIEVE THE HEAD PRESSURE. See Figure 1 below.

BATTERY CONNECTION INSTRUCTIONS FOR ELECTRIC START ENGINES

Note: Make sure to follow instructions carefully to avoid a short and possible damage to the starter solenoid and/or battery.

1. Connect the positive (+) terminal on the battery to the starter solenoid.
2. Connect the negative (-) terminal on the battery to an engine mounting bolt or other acceptable ground connection.

Always connect the positive (+) battery cable to the starter solenoid before connecting the negative (-) battery cable.

NUMBER 2 WIRE OR LARGER IS REQUIRED

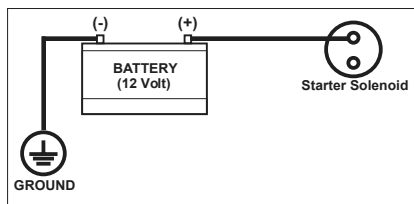

COLD START PROCEDURE (GASOLINE ENGINE UNITS)

⚠ WARNING

DO NOT operate gasoline engine units in an enclosed area.

- Release any remaining tank pressure by slowly opening the manual drain valve.
- Turn on the engine gasoline supply.
- Put the choke in the "On" position.
- Close the service valve and put Unloader lever in the "unload" (A) Position for Briggs and Stratton and Honda engine driven models, or the "load" (B) position for Kohler engine models.
- Start the engine, release the choke, and allow the engine to warm up for two to three minutes.
- Return the unloader lever to the "load" (B) position on Briggs and Stratton and Honda driven models.

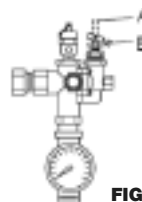

FIGURE 1

NOTE: Turn the gasoline supply off when the compressor is not being used.



AIR COMPRESSOR

⚠ WARNING

Oil and moisture residue must be drained from the air receiver daily or after each use. Accumulations of oil residue in the receiver can be ignited by embers of carbon created by the heat of compression causing an explosion, damage to property and injury to personnel.

⚠ WARNING

DO NOT open a manual tank drain valve on any air tank containing more than 30 PSIG of air pressure!

⚠ WARNING

Never attempt to relieve an air tank by removing a pipe plug or any other system component!

AIR TANK INSPECTION

Recommended Air Tank Inspection Intervals The factory recommends that all air tanks be inspected at scheduled intervals. Refer to Recommended Air Tank Inspection Intervals Table for relative information.

Refer to federal, state or provincial, or local codes for mandatory air tank maintenance information.

PUMP SPECIFICATIONS

Pump Model	Pump P/N	Cyl. No.	Stages
PAT24	4116091136	2	1
PAT38	4116091337	2	1
T39	4116090019	2	2
T29S	4116090112	2	2
B5900	4116090137	2	2
C1	1312202800	2	2
C2	1312202700	4	2

Pump Model	Cyl. Diam. In. (mm)		Stroke In. (mm)	Max RPM	Oil Cap. Qt. (L)	Displacement @ max RPM	
	1st Stg	2nd Stg				CFM	L/M
PAT24	2.48 (63)	N/A	1.50 (38)	1400	.56 (0.53)	11.71	331.59
PAT38	2.48 (63)	N/A	2.36 (60)	1400	.91 (.86)	18.49	523.58
T39	4.13 (105)	2.05 (52)	2.95 (60)	1400	1.09 (1.03)	32.02	906.63
T29S	3.74 (85)	1.97 (45)	1.97 (45)	1400	1.44 (1.36)	17.53	496.50
B5900	4.13 (105)	2.16 (55)	2.16 (55)	1400	1.72 (1.63)	23.44	663.84
C1	4.13 (105)	2.16 (55)	3.5 (89)	1000	1.31 (1.24)	27.13	768.33
C2	4.13 (105)	2.16 (55)	3.5 (89)	900	1.5 (1.42)	48.84	1382.99

Pump Model	Bolt Torque Ft./Lbs. (NM)				
	Conrod	Head	Cylinder	Bearing Housing	Flywheel
PAT24	N/A	18-20 (24-27)	18-20 (24-27)	5-7 (7-10)	18-20 (24-27)
PAT38	N/A	18-20 (24-27)	18-20 (24-27)	5-7 (7-10)	18-20 (24-27)
T39	20-22 (27-30)	30-33 (40-45)	16-19 (22-26)	19-22 (26-30)	34-37 (46-50)
T29S	18-20 (24-27)	18-20 (24-27)	18-20 (24-27)	5-7 (7-10)	18-20 (24-27)
B5900	18-20 (24-27)	18-20 (24-27)	18-20 (24-27)	5-7 (7-10)	18-20 (24-27)
C1	34-37 (46-50)	34-37 (46-50)	19-27 (26-37)	14-19 (19-26)	47-57 (64-77)
C2	34-37 (46-50)	34-37 (46-50)	19-27 (26-37)	14-19 (19-26)	47-57 (64-77)

MANUALLY DRAINING AN AIR TANK:

- Step 1) Disconnect and lockout the compressor from the power source (electric models) or disconnect the spark plug wire from the spark plug (gas engine models).
- Step 2) Tank(s) subjected to freezing temperatures may contain ice. Store the compressor in a heated area before attempting to drain moisture from the tank(s). Reduce the air pressure in the tank to 30 PSIG by pulling the pressure relief valve ring.
- Step 3) Slowly open the drain valve and allow the moisture and air mixture to drain from the tank.
- Step 4) Once the moisture has been completely drained, close the drain valve.

RECOMMENDED AIR TANK INSPECTION

Tank Capacity	Horizontal or Vertical	Minimum Allowance Call		Visually Inspect	Hydrostatically Inspect
		Head	Shell		
8 Gal.	Horizontal	0.096	0.094	Yearly	10 Years
8 Gal.	Twin Horz.	0.098	0.098	Yearly	10 Years
10 Gal.	Twin Horz.	0.118	0.118	Yearly	10 Years
20 Gal.	Horizontal	0.094	0.094	Yearly	10 Years
26 Gal.	Vertical	0.094	0.094	Yearly	10 Years
30 Gal.	Horizontal	0.109	0.098	Yearly	10 Years
60 Gal.	Vertical	0.094	0.094	Yearly	10 Years
80 Gal.	Vertical	0.149	0.133	Yearly	10 Years
80 Gal.	Horizontal	0.109	0.133	Yearly	10 Years
120 Gal.	Vertical	0.163	0.199	Yearly	10 Years
120 Gal. & Duplex	Horizontal	0.131	0.159	Yearly	10 Years
200 Gal. Duplex	Horizontal	0.163	0.199	Yearly	10 Years

TANK SPECIFICATIONS

Volume	Max Pressure.	Discharge Conn		
		Gal.	Liter	NPT
20H	150	76	10.345	1/4"
26V	150	99	10.345	1/4"
60V	170	228	11.724	1/2"
2X4	200	2X15.2	13.793	3/8"
2X5	200	2X19	13.793	3/8"
80H	200	228	13.793	3/4"
80V	200	300	13.793	3/4"
30H	200	114	13.793	3/4"
120V	200	456	13.793	3/4"
120H	200	456	13.793	3/4"
120D	200	456	13.793	3/4"
200D	200	760	13.793	3/4"





AIR COMPRESSOR

TROUBLESHOOTING GUIDE

<p>Low discharge pressure</p>	<ol style="list-style-type: none"> Compressor too small for application Air leaks Restricted intake air Blown gasket(s) Broken or misaligned valves 	<ol style="list-style-type: none"> Reduce air demand or use a compressor with more air capacity. Listen for air leaks. Apply a soap solution to all fittings and connections. Bubbles will form at points of leakage. Tighten or replace fittings or connections. Clean or replace air filter. Replace necessary gaskets. Remove head and inspect for broken or misaligned valves. Replace valves, if necessary. <p>CAUTION Install a new head gasket each time head is removed</p>
<p>Excessive noise knocking</p>	<ol style="list-style-type: none"> Loose drive pulley or flywheel Low on oil Worn connecting rod or connecting rod bearing Noisy check valve 	<ol style="list-style-type: none"> Tighten drive pulley or flywheel bolt. Check for proper oil level. Low or dirty oil may cause bearing damage. Replace connecting rod and/or connecting rod bearings. Replace check valve. <p>DANGER DO NOT remove check valve with air pressure in tank</p>
<p>Excessive oil carryover</p>	<ol style="list-style-type: none"> Worn piston rings Restricted intake air Too much oil in compressor Incorrect oil viscosity 	<ol style="list-style-type: none"> Replace with new piston rings. Clean or replace air filter. Drain oil to proper oil level. Use a quality non-detergent 30 or 40 wt oil specified for each model (Page 4).
<p>Water in tank and/or discharge line</p>	<ol style="list-style-type: none"> Normal. Amount of water will increase as humidity in the air increases. 	<ol style="list-style-type: none"> Drain tank at least once per day. Add an in-line filter to reduce moisture in the air line.
<p>Will not run or motor hums</p>	<ol style="list-style-type: none"> Low voltage Malfunctioning pressure switch Malfunctioning check valve 	<ol style="list-style-type: none"> Check voltage with volt meter across both legs of incoming power. Check reset button on motor. Repair or replace pressure switch. Replace check valve or pressure switch. <p>DANGER DO NOT remove check valve with air pressure in tank</p>
<p>Breaker or reset repeatedly trips</p>	<ol style="list-style-type: none"> Incorrect breaker size Low voltage Malfunctioning motor Loose electrical connections Malfunctioning pressure switch Malfunctioning check valve 	<ol style="list-style-type: none"> Make sure the breaker is sized properly. See page 6 in this manual. Check voltage with volt meter across both legs of incoming power. Replace motor. Check all electrical connections. Adjust or replace pressure switch. Replace check valve. <p>DANGER DO NOT remove check valve with air pressure in tank</p>
<p>Tank does not hold pressure when not running and shut off valve is closed</p>	<ol style="list-style-type: none"> Malfunctioning check valve Loose fittings or connections Crack or pin hole in tank 	<ol style="list-style-type: none"> Replace check valve. Tighten or replace fittings or connections. Replace tank. Do not attempt to repair tank. <p>DANGER DO NOT remove check valve with air pressure in tank</p>
<p>Pressure switch unloader constantly leaking air</p>	<ol style="list-style-type: none"> Malfunctioning check valve 	<ol style="list-style-type: none"> Replace check valve if unloader bleeds constantly. <p>DANGER DO NOT remove check valve with air pressure in tank</p>
<p>Pressure switch not unloading</p>	<ol style="list-style-type: none"> Malfunctioning pressure switch 	<ol style="list-style-type: none"> Replace pressure switch if it does not release air pressure briefly when unit shuts off. <p>DANGER DO NOT remove check valve with air pressure in tank</p>
<p>Excessive vibration</p>	<ol style="list-style-type: none"> Improper installation Loose belts Misaligned flywheel or drive pulley 	<ol style="list-style-type: none"> Make sure unit is mounted on a level surface with vibration pads. Replace belts. Align and tighten properly. Align flywheel and drive pulley.
<p>Overheating</p>	<ol style="list-style-type: none"> Compressor too small for application Cooling surfaces dirty Improper cooling 	<ol style="list-style-type: none"> Reduce air demand or use a compressor with more air capacity. Clean all cooling surfaces of dirt and dust. Install compressor in an area with adequate cool dry air.



AIR COMPRESSOR

Chicago Pneumatic Full Two-Year Warranty Statement

The Company warrants that the Equipment manufactured by it and delivered hereunder shall be free from defects in material and workmanship for a period of twenty four (24) Months from the date of initial start-up, or twenty four (24) Months from the date of shipment from the manufacturer, whichever occurs first. The foregoing warranty period shall apply to all Equipment, except for the following: (A) all two stage reciprocating stationary models are warranted for the earlier of twenty-four (24) Months from the date of initial operation or thirty (30) months from date of shipment from the manufacturer. (B) Replacement parts will be warranted for three (3) months from the date of shipment from the manufacturer. Should the failure to conform to this warranty be reported in writing to the Company within said period, the Company shall, at its option, correct such non-conformity by suitable repair to such Equipment, or furnish a replacement part F.O.B point of shipment, provided that the Purchaser has installed, maintained, and operated such Equipment in accordance with good industry practices, and has complied with specific recommendations of the Company. Accessories and equipment furnished by the Company, but manufactured by others, shall carry whatever warranty the manufacturer conveyed to the Company and which can be passed on to the Purchaser. The Company shall not be liable for any repairs, replacements, or adjustments to the Equipment, or any costs of labor performed by the Purchaser without the Company's prior written approval.

The Company makes no performance warranty unless specifically stated within its proposal, and the effects of corrosion, erosion, and normal wear and tear are specifically excluded from the Company's warranty. In the event performance warranties are expressly included, the Company's obligation shall be to correct in the manner and for the period of time provided above.

THE COMPANY MAKES NO OTHER WARRANTY OR REPRESENTATION OF ANY KIND WHATSOEVER, EXPRESSED OR IMPLIED, EXCEPT THAT OF TITLE, AND ALL IMPLIED WARRANTIES OF MERCHANTABILITY AND FITNESS FOR A PARTICULAR PURPOSE, ARE HEREBY DISCLAIMED. THIS WARRANTY SUPERSEDES ALL PREVIOUS WARRANTY STATEMENTS.

Correction by the Company of non-conformities, whether patent or latent, in the manner and for the period of time provided above, shall constitute fulfillment of all liabilities of the Company and its distributors for such non-conformities with respect to, or arising out of such Equipment.

LIMITATION OF LIABILITY

THE REMEDIES OF THE PURCHASER SET FORTH HEREIN ARE EXCLUSIVE, AND THE TOTAL LIABILITY OF THE COMPANY, ITS DISTRIBUTORS AND SUPPLIERS WITH RESPECT TO CONTRACT OR THE EQUIPMENT AND SERVICES FURNISHED IN CONNECTION WITH THE PERFORMANCE OR BREACH THEREOF, OR FROM THE MANUFACTURE, SALE, DELIVERY, INSTALLATION, REPAIR OR TECHNICAL DIRECTION COVERED OR FURNISHED UNDER CONTRACT, WHETHER BASED ON CONTRACT, WARRANTY, NEGLIGENCE, INDEMNITY, STRICT LIABILITY OR OTHERWISE, SHALL NOT EXCEED THE PURCHASE PRICE OF THE EQUIPMENT UPON WHICH SUCH LIABILITY IS BASED.

THE COMPANY, ITS DISTRIBUTORS AND ITS SUPPLIERS SHALL IN NO EVENT BE LIABLE TO THE PURCHASER, ANY SUCCESSORS IN INTEREST, OR ANY BENEFICIARY OR ASSIGNEE OF THE CONTRACT FOR ANY CONSEQUENTIAL, INCIDENTAL, INDIRECT, SPECIAL OR PUNITIVE DAMAGES ARISING OUT OF THIS CONTRACT OR ANY BREACH THEREOF, OR ANY DEFECT IN, OR FAILURE OF, OR MALFUNCTION OF THE EQUIPMENT, WHETHER OR NOT BASED ON LOSS OF USE, LOST PROFITS OR REVENUE, INTEREST, LOST GOODWILL, WORK STOPPAGE, IMPAIRMENT OF OTHER GOODS, LOSS BY REASON OF SHUTDOWN OR NON-OPERATION, COST OF PURCHASE OF REPLACEMENT POWER, OR CLAIMS OF PURCHASER OR CUSTOMERS OF PURCHASER FOR SERVICE INTERRUPTION, WHETHER OR NOT SUCH LOSS OR DAMAGE IS BASED ON CONTRACT, WARRANTY, NEGLIGENCE, INDEMNITY, STRICT LIABILITY OR OTHERWISE.

For warranty information call Chicago Pneumatic 1-886-869-3114 (Parts and Technical)

CONTACT US

3580 E. Raines Road, Suite 3, Memphis, TN 38118
Tel: 1-866-458-2472
www.oem-tools.com