

Please read and save these instructions. Read through this owner's manual carefully before using product. Protect yourself and others by observing all safety information, warnings, and cautions. Failure to comply with instructions could result in personal injury and/or damage to product or property. Please retain instructions for future reference.



14" CHOP SAW

FOR CUSTOMER SERVICE

Technical Question?

CALL 1-866-458-2472
customerservice@oem-tools.com

UNPACKING

After unpacking unit, inspect carefully for any damage that may have occurred during transit. Check for loose, missing, or damaged parts. If any damage is observed, a shipping damage claim must be filed with carrier. **DO NOT** use the OEMTOOLS™ Chop Saw if broken, bent, cracked or damaged parts (including labels) are noted. Any Chop Saw that appears damaged in any way, operates abnormally or is missing parts should be removed from service immediately. If you suspect that the Chop Saw was subjected to shock load (a load that was dropped suddenly, unexpectedly, etc.) immediately discontinue use until it has been checked by a factory authorized service center.



⚠ WARNING

The following safety information is provided as a guideline to help you operate your Chop Saw under the safest possible conditions. Any tool or piece of equipment can be potentially dangerous to use when safety or safe handling instructions are not known or not followed. The following safety instructions are to provide the user with the information necessary for safe use and operation. Please read and retain these instructions for the continued safe use of your service system. Failure to follow instructions listed below may result in serious injury. In addition, make certain that anyone who uses the equipment understands and follows these safety instructions as well.

Explanation of Safety Signal Words

⚠ WARNING: Indicates a potentially hazardous situation which, if not avoided, could result in death or serious injury.

⚠ CAUTION: Indicates a potentially hazardous situation which, if not avoided, may result in minor or moderate injury.

CAUTION: Used without the safety alert symbol indicates a potentially hazardous situation which, if not avoided, may result in property damage.

NOTES: Provide clarity and helpful information.

Thank you very much for choosing an OEMTOOLS™ Product!

For future reference, please register your new tool at www.oem-tools.com and complete the owner's record below:

Model: _____ **Purchase Date:** _____

Save the receipt, warranty and these instructions. It is important that you read the entire manual to become familiar with this product before you begin using it. This product is designed for certain applications only. OEMTOOLS™ cannot be responsible for issues arising from modification. We strongly recommend this product is not modified and/or used for any application other than that for which it was designed. If you have any questions relative to a particular application, **DO NOT** use the product until you have first contacted customer service to determine if it can or should be performed on the product.

⚠ WARNING: This product can expose you to chemicals, including benzyl violet 4B, which are known to the State of California to cause cancer and birth defects or other reproductive harm. For more information, go to www.P65Warnings.ca.gov.



14" CHOP SAW

POWER TOOL SAFETY

⚠WARNING: Read and understand all instructions. Failure to follow all instructions listed below may result in electric shock, fire, and/or serious personal injury.

WORK AREA SAFETY

1. Keep work area clean and well lit. Cluttered or dark areas invite accidents.
2. DO NOT operate power tools in explosive atmospheres, such as in the presence of flammable liquids, gases or dust. Power tools create sparks which may ignite the dust or fumes.
3. Keep children and bystanders away while operating a power tool. Distractions can cause you to lose control.

ELECTRICAL SAFETY

1. Double insulated tools are equipped with a polarized plug (one blade is wider than the other). This plug will fit in a polarized plug only one way.
2. If the plug does not fit fully into the outlet, reverse the plug. If it still does not fit, contact a qualified electrician to install a polarized outlet. DO NOT alter the plug in any way. Double insulation eliminates the need for the three-prong grounded power cord and grounded power supply system.
3. Avoid body contact with grounded surfaces such as pipes, radiators, ranges and refrigerators. There is increased risk of electric shock if your body is grounded.
4. DO NOT expose power tools to rain or wet conditions. Water entering the power tool will increase the risk of electric shock.
5. DO NOT abuse the cord. Never use the cord to carry the tool or pull the plug from an outlet. Keep cord away from heat, oil, sharp edges or moving parts. Replace damaged cords immediately. Damaged cords increase the risk of electric shock.
6. When operating a power tool outdoors, use an outdoor extension cord marked "W-A" or "W". These cords are rated for outdoor use and reduce the risk of electric shock.
7. When not in use, disconnect from the power source and store in a safe, dry childproof location.

PERSONAL SAFETY

1. Stay alert, watch what you are doing and use common sense when operating a power tool. DO NOT use a power tool while you are tired or under the influence of drugs, alcohol or medication. A moment of inattention while operating power tools may result in serious personal injury.
2. Use personal protective equipment. Always wear eye protection. Protective equipment such as dust mask, non-skid safety shoes, hard hat, or hearing protection used for appropriate conditions will reduce personal injuries.
3. Prevent unintentional starting. Ensure the switch is in the OFF position before connecting to power source and/or battery pack, picking up or carrying the tool. Carrying power tools with your finger on the switch or energizing power tools that have the switch on invites accidents.

4. Remove any adjusting key or wrench before turning the power tool on. A wrench or a key left attached to a rotating part of the power tool may result in personal injury.
5. DO NOT overreach. Keep proper footing and balance at all times. This enables better control of the power tool in unexpected situations.
6. Dress properly. DO NOT wear loose clothing or jewelry. Keep your hair, clothing and gloves away from moving parts. Loose clothes, jewelry or long hair can be caught in moving parts.
7. If devices are provided for the connection of dust extraction and collection facilities, ensure these are connected and properly used. Use of dust collection can reduce dust related hazards.

TOOL USE AND CARE

1. DO NOT force the power tool. Use the correct power tool for your application. The correct power tool will do the job better and safer at the rate for which it was designed.
2. DO NOT use the power tool if the switch does not turn it on and off. Any power tool that cannot be controlled with the switch is dangerous and must be repaired.
3. Disconnect the plug from the power source and/or the battery pack from the power tool before making any adjustments, changing accessories, or storing power tools. Such preventive safety measures reduce the risk of starting the power tool accidentally.
4. Store idle power tools out of the reach of children and DO NOT allow persons unfamiliar with the power tool or these instructions to operate the power tool. Power tools are dangerous in the hands of untrained users.
5. Maintain power tools. Check for misalignment or binding of moving parts, breakage of parts and any other condition that may affect the power tool's operation. If damaged, have the power tool repaired before use. Many accidents are caused by poorly maintained power tools.
6. Keep cutting tools sharp and clean. Properly maintained cutting tools with sharp cutting edges are less likely to bind and are easier to control.
7. Use the power tool, accessories and tool bits etc. in accordance with these instructions, taking into account the working conditions and the work to be performed. Use of the power tool for operations different from those intended could result in a hazardous situation.
8. Hold the power tool by insulated gripping surfaces when performing an operation where the cutting tool may contact hidden wiring or its own cord. Contact with a "live" wire will make exposed metal parts of the tool "live" and shock the operator.
9. Use clamps or other practical ways to secure and support the workpiece to a stable platform. Holding the workpiece by hand or against your body leaves it unstable and may lead to loss of control.

SERVICE

Have your power tool serviced by a qualified repair person using only identical replacement parts. This will ensure that the safety of the power tool is maintained.



14" CHOP SAW

SPECIFIC SAFETY RULES

▲WARNING

1. Know your Chop Saw. Carefully read and understand this Instruction Manual. Learn the tool's applications and limitations, as well as the specific potential hazards related to this tool. Following this rule will reduce the risk of electric shock, fire, or serious injury.
2. Always wear eye protection. Any power tool can throw foreign objects into your eyes and cause permanent eye damage. ALWAYS wear safety goggles (not glasses) that comply with ANSI safety standard Z87.1. Everyday glasses have only impact resistant lenses. They ARE NOT safety glasses.
3. Glasses or goggles not in compliance with ANSI Z87.1 could cause serious injury when they break.
4. Always wear hearing protection and a dust mask. Use only in a well-ventilated area. Using personal safety devices and working in a safe environment reduces the risk of injury.

▲WARNING

Always unplug the tool from the power source before changing the cutting disc or when cleaning the tool.

▲WARNING

Never place your hands or fingers near the cutting disc while the tool is running. Severe injury will result.

▲WARNING

Never install a saw blade on this tool. It is designed ONLY for use with abrasive cut-off discs.

5. Use this Chop Saw for cutting steel only. Cutting ceramic materials will create excessive dust and cause damage to the motor.
6. Always use a dust mask along with safety goggles when operating the Chop Saw.
7. Always use hearing protection when operating of the Chop Saw.
8. DO NOT wear gloves, neckties or loose clothing.
9. DO NOT cut material too small to be securely held in the vise.
10. Always keep your hands out of the path of the cut-off disc. Avoid awkward hand positions where a sudden slip could cause your hand to move into the path of the cut-off disc.
11. Secure the workpiece. Use the clamping system provided with the Chop Saw. It is safer than using your hand.
12. Make sure there are no foreign objects in the part of the workpiece to be cut.
13. The cut-off disc must be securely attached as described in this Owner's Manual before connecting the tool to the power source. Failure to do so will increase the risk of serious injury if the cut-off disc shatters or comes loose.
14. Make sure the guard is installed and in proper working order before operating the Chop Saw.
15. Cut-off discs must be stored in a dry location to prevent deterioration.
16. Before attaching the cut-off disc, inspect it for visible defects. If cracked, chipped or warped, DO NOT install it.
17. DO NOT over tighten the clamp nut on the cut-off disc. Excessive tightening may cause the disc to crack and possibly shatter during operation.

18. Never turn the Chop Saw ON with the cut-off disc touching the work surface.
19. Use only cut-off discs in compliance with ANSI Standard B7.1 and rated for a speed greater than 3500 RPM.
20. DO NOT use the Chop Saw if the disc flanges or cap screws are missing or improperly installed.
21. Dust and abrasive materials should not be allowed to build up in the workshop. Hot metal sparks could start a fire.
22. DO NOT remove the soft paper in the centre of the cut-off disc.
23. DO NOT alter or enlarge the center hole of the cut-off disc as this could result in the disc shattering.

▲WARNING

Use only cut-off discs that are recommended for this Chop Saw. Follow the instructions that accompany the cut-off discs. The use of improper cut-off discs may result in injury to the operator or damage to the Chop Saw.

▲WARNING

To avoid fire or toxic reaction, never use gasoline, naphtha, acetone, lacquer thinner or similar highly volatile solvents to clean the tool.

▲ ELECTRICAL WARNING

POWER SOURCE CONNECTION POWER REQUIREMENTS

This product is designed to operate on a properly grounded 120 volt, 60Hz, single-phase alternating current (AC) power source fused with a time delayed fuse or circuit breaker. It is recommended that a qualified electrician verify the ACTUAL VOLTAGE at the receptacle into which the product will be plugged and confirm that the receptacle is properly fused and grounded.

DO NOT OPERATE THIS PRODUCT if the ACTUAL power source voltage is less than 105 Volts AC or greater than 132 Volts AC. Contact a qualified electrician if this problem exists. Improper performance and/or damage to the product will result if operated on inadequate or excessive power.

DO NOT abuse cord. Never use the cord to carry tools or pull the plug from an outlet. Keep cord away from heat, sharp edges or moving parts. Replace damaged cords immediately. Damaged cords increase the risk of electric shock.

EXTENSION CORD SAFETY

▲WARNING

Keep the extension cord clear of the working area. Position the cord so it will not get caught on the workpiece, tools or any other obstructions while you are working with the power tool.

1. Make sure any extension cord used with this tool is in good condition. When using an extension cord, be sure to use one of heavy enough gauge to carry the current the tool will draw. An undersized cord will cause a drop in line voltage resulting in loss of power and overheating.
2. The table below shows the correct size to use according to cord length and nameplate ampere rating. If in doubt, use the next heavier gauge. The smaller the gauge number the heavier the cord.



14" CHOP SAW

3. Be sure your extension cord is properly wired and in good condition. Always replace a damaged extension cord or have it repaired by a qualified electrician before using it. Protect your extension cord from sharp objects, excessive heat and damp or wet areas.
4. Use a separate electrical circuit for your power tools. This circuit must not be less than 14 gauge wire and should be protected with either a 15 A time delayed fuse or circuit breaker. Before connecting the power tool to the power source, make sure the switch is in the OFF position and the power source is the same as indicated on the nameplate. Running at lower voltage will damage the motor.

MINIMUM GAUGE (AWG) EXTENSION CORDS (120 V use only)					
Amperage rating		Total length			
More than	Not more than	25' (7.5 m)	50' (15 m)	100' (30 m)	150' (45 m)
0	6	18	16	16	14
6	10	18	16	14	12
10	12	16	16	14	12
12	16	14	12	Not Applicable	

IMPORTANT SAFETY INSTRUCTIONS

The warnings, precautions, and instructions discussed in this manual cannot cover all possible conditions and situations that may occur. The operator must understand that common sense and caution are factors which cannot be built into this product, but must be supplied by the operator.

⚠️WARNING

Use only attachments recommended or sold by manufacturer. Verify the following every time the Chop Saw is used. Failure to adhere to these safety rules can greatly increase the chances of serious injury.

1. DO NOT disassemble the saw. Take it to a qualified professional when service or repair is required. Incorrect reassembly may result in electric shock or fire.
2. Wear approved safety eye/face shield, ear defenders and hand protection.
3. The power cord is not damaged.
4. The cut-off disc is correct for the type of material being cut.
5. The cut-off disc is in good condition and securely tightened onto the arbor.
6. The guard is in good working order.
7. No flammable liquids are in the vicinity.

DISPOSAL

At the end of the useful life of the OEMTOOLS™ 14" Chop Saw, dispose of the components according to all state, federal and local regulations.

PURPOSE

The OEMTOOLS™ 14" Chop Saw is designed to slice through metal and other tough materials. It will cut pipe, fence posts, tubing and other dense materials. The included vise holds the workpiece safely and securely.

PRODUCT SPECIFICATIONS

Power:	15 Amp
No-Load Speed:	3,800 RPM
Disc Diameter:	14"
Clamping Vise:	Yes
Arbor:	1"
Max. Cutting Depth:	4.72" Round Pipe
Max. Cutting Depth:	4.33" Square
Power Cord Length:	6 Ft.
Weight:	33 Lbs.

INSTRUCTIONS

Always wear safety goggles and gloves.

ASSEMBLY AND OPERATION

⚠️WARNING

Always disconnect your Chop Saw from the power source when replacing the cut-off disc, clamping material in the vise, adjusting the guard, cleaning or when not in use. Disconnecting the Chop Saw will prevent accidental starting that could cause serious personal injury.

SELECTING THE WORK SURFACE

It is important to place the Chop Saw on a solid flat work surface that will not shift during operation of the Chop Saw. Locating the Chop Saw near an electrical outlet will eliminate the need for an extension cord.

⚠️WARNING

Never place the Chop Saw near any flammable liquids or items that can be damaged by the sparks thrown by the Chop Saw during cutting. The hot sparks can ignite flammable liquids.

NOTE: Hot metal sparks and sharp metal pieces will damage the work surface to some degree. Make sure you consider this fact when selecting the work surface. A nonflammable surface such as a metal bench will be less likely to be damaged during the cutting operation.



14" CHOP SAW

SETTING THE DEPTH STOP

NOTE: The maximum cut depth is controlled by adjusting the depth stop.

1. Lift the swing arm upward as far as it will go. (Figure 1)

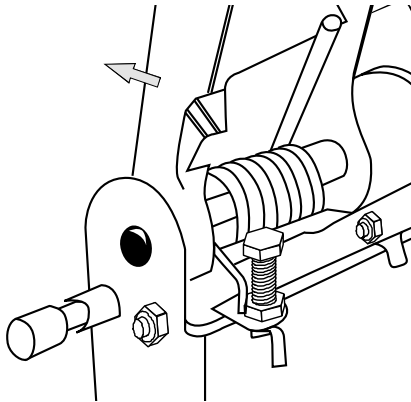

Figure 1

2. Loosen the depth stop lock nut by turning it counterclockwise.
3. Turn the depth stop screw to raise or lower it. Adjust until the cut-off blade enters the base slot no more than 3/16" (5 mm) when the swing arm is fully lowered and contacts the top of the depth stop screw.
4. When the depth stop screw is correctly set, lock it in place by tightening the lock nut clockwise.

CHECKING THE AUTOMATIC GUARD

The automatic guard must be checked to ensure it is working properly.

▲WARNING

Always disconnect your Chop Saw from the power source before checking the automatic guard.

1. Lift the guard upward approximately 3" and then release it. (Figure 2) If the guard is functioning correctly, it will freely drop down to its original position.

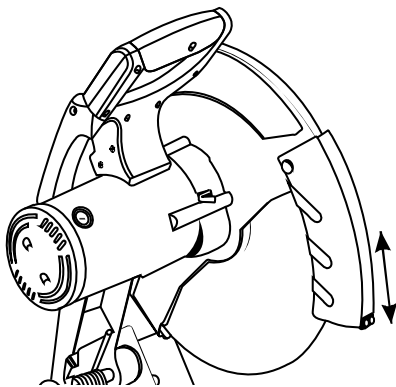

Figure 2

2. Lower the swing arm and cutting disc assembly until the lower edge of the guard touches the Chop Saw base. Continue to lower the swing arm and cutting disc assembly. The automatic guard should freely rise as the cutting disc is lowered.

NOTE: The guard should always rise and fall freely when the swing arm is lowered and raised as outlined in #1 and #2. If not, clean any cuttings out from around the guard mechanism. (Figure 3)

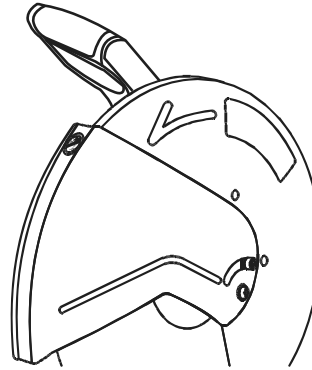

Figure 3

CHECKING THE ARBOR CAP SCREW

It is important to check the arbor cap screw to make sure the cut-off disc is fully tightened.

▲WARNING

Disconnect your Chop Saw from the power source before checking the arbor cap screw.

1. Lift swing arm fully upward as far as it will go.
2. Lift the disc guard fully upward until it will stay in the upright position. (Figure 4)

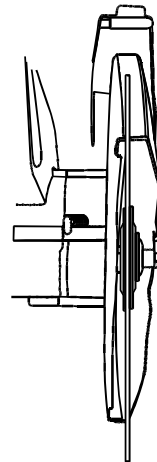

Figure 4

3. Press and hold the arbor lock to the right while rotating the cut-off disc by hand.
4. When the arbor lock engages the arbor, tighten the arbor cap screw by turning it clockwise using the 8 mm hex key supplied.

NOTE: Only use the hex key supplied to tighten the arbor cap screw. DO NOT over tighten the arbor cap screw as you could crack the hub of the cutting disc.

5. When the arbor cap screw is fully tightened, remove the hex key, release the arbor lock and lower the disc guard.



14" CHOP SAW

SETTING THE MITRE VISE ANGLE

The mitre vise can be set for cutting at angles from 90° to 45° either left or right.

1. Open the vise by turning the vise adjustment crank 5 or 6 turns counterclockwise. (Figure 5)

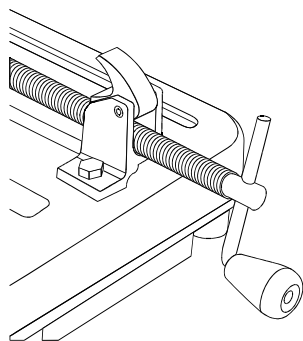

Figure 5

2. Loosen the mitre gauge cap screws by turning them counterclockwise using the 8 mm hex key supplied. (Figure 6)

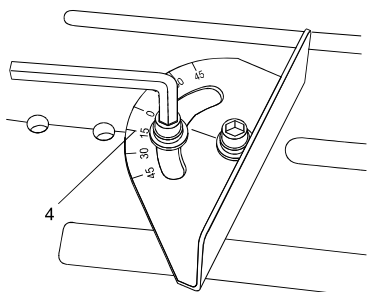

Figure 6

3. Rotate the mitre gauge to the left or right until the desired cutting angle lines up with the alignment mark.
4. Tighten both the mitre gauge cap screws to lock the mitre gauge in place.

NOTE: Always make a test cut on a scrap workpiece to verify the mitre angle setting.

CUTTING UP TO 5" WIDE WORKPIECES

The vise is set up at the factory for cutting workpieces up to 5" in width. This is the preferred set-up. If it is necessary to cut workpieces between 5" and 7" in width, the mitre gauge will have to be relocated on the Chop Saw base.

1. Remove the front and rear mitre gauge cap screws using the 8 mm hex key supplied. (Figure 7)

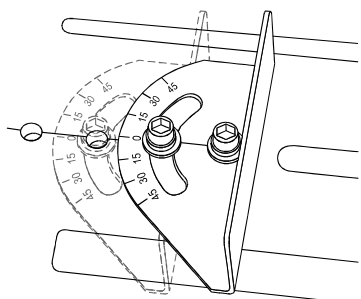

Figure 7

2. Move the mitre gauge back approximately 1-1/2" until the hole and slot in the mitre gauge line up with the next two holes in the Chop Saw base.
3. Reinstall and tighten the mitre gauge cap screws in the two new holes.

NOTE: To cut workpieces between 7" and 9" in width, locate the mitre gauge in the back two holes in the Chop Saw base.

OPERATING THE VISE QUICK RELEASE

The vise has a quick release feature that allows for making major adjustments much quicker.

1. To operate the quick release system, turn the vise crank counterclockwise 2 or 3 turns to loosen the vise jaws. (Figure 8)

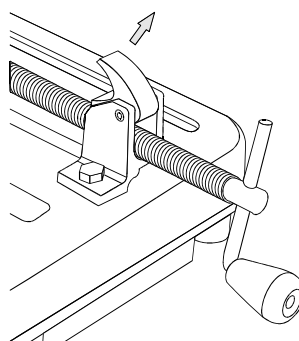

Figure 8

2. Lift upward on the front of the quick release nut to release the vise screw.
3. While holding the quick release nut upward in the released position, pull the vise crank toward you to quickly open the vise.
4. To quickly close the vise, release the quick release nut and push the crank away from you.
5. Use the crank to completely tighten the vise on the workpiece.

⚠ WARNING

Always make sure the workpiece is flat against the Chop Saw base and securely held in the vise before turning the saw ON.

ON/OFF SWITCH

1. To turn the switch ON, squeeze the trigger switch until the Chop Saw starts. During operation, you should continue to squeeze the trigger switch. (Figure 9)

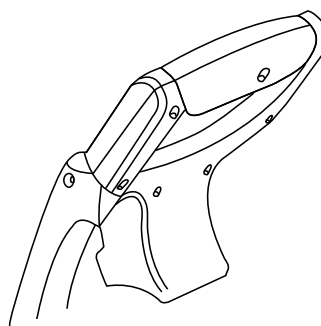

Figure 9

2. To turn the tool OFF, release the trigger switch.



14" CHOP SAW

⚠ WARNING

Always make sure the cut-off disc is NOT touching the workpiece when the switch is being turned ON. Let the motor come to full speed before beginning to cut.

REPLACING THE CUT-OFF DISC

The cut-off disc must be replaced when it has become damaged in any way or it has worn down to a diameter of less than 10".

⚠ WARNING

Disconnect your Chop Saw from the power source before attempting to change the cut-off disc.

1. Lift the swing arm fully upward.
2. Lift the guard fully upward until it exposes the arbor cap screw. (Figure 10)

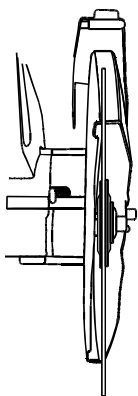

Figure 10

3. Press and hold the arbor lock to the right while rotating the cut-off disc by hand.
4. When the arbor lock engages the arbor, loosen the arbor cap screw by turning it counterclockwise using the 8 mm hex key supplied.
5. Remove the arbor cap screw, the small outer washer, the large outer washer, the cut-off disc and large inner washer from the arbor. (Figure 11)

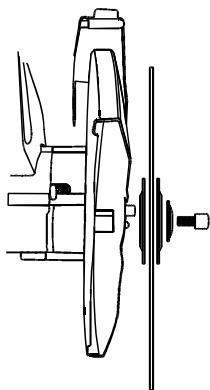

Figure 11

6. Use a clean dry brush or cloth to carefully remove all cuttings from the arbor and the motor housing.
7. Reinstall the washers, new cut-off disc and arbor cap screw in the same order in which they were removed.

NOTE: Make sure the large outer surfaces of the large and small washers are facing the cut-off disk. Make sure the flats of the washer holes slide over the matching flats of the arbor.

8. Engage the arbor lock and tighten the arbor cap screw using the 8 mm hex key supplied.
9. Carefully rotate the cut-off disk by hand to make sure it is firmly tightened, that it is not damaged and that it does not wobble.

⚠ WARNING

Reset the depth stop as shown in Fig. 1. The new blade will be larger and will damage the work surface if the depth stop is not readjusted.

10. With the depth stop properly set and the guard in the down position, turn the switch ON.

NOTE: If the cut-off disc wobbles or vibrates, turn the switch OFF immediately. Recheck to make sure the cut-off disc is installed correctly and that the disc is not damaged.

LOCKING THE SWING ARM FOR CARRYING

To safely carry the Chop Saw, it is important to lock the swing arm and carry the tool with the appropriate carrying handle.

1. Lower the swing arm as far as it will go. (Figure 12)

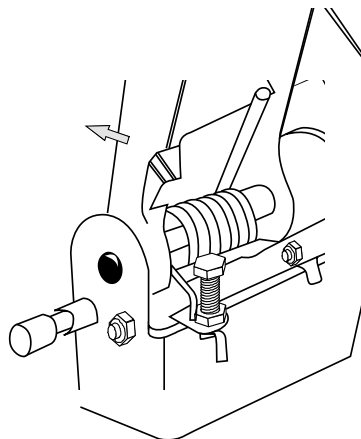

Figure 12

2. Push inward on the swing arm locking pin until it engages the hole in the swing arm.
3. Release the swing arm. It will be locked in the DOWN position if the swing arm locking pin is properly engaged.
4. Lift the Chop Saw using the rear handle.

CUTTING METAL

1. Lift the swing arm fully upward as far as it will go.
2. Adjust the mitre gauge as required.
3. Firmly lock the metal workpiece to be cut in the vise.
4. Make sure you are wearing your safety goggles, dust mask and hearing protection.
5. Lower the cut-off disc until it is about 1" above the workpiece.

NOTE: The cut-off disc MUST NOT be touching the workpiece when the motor switch is turned ON.

6. While holding the Chop Saw handle firmly in your right hand, turn the motor switch ON.



14" CHOP SAW

7. Wait for the motor to come up to its full speed. Carefully lower the cut-off disc until it contacts the workpiece.
- NOTE:** Many sparks will be generated as soon as the cut-off disc touches the workpiece.
8. Apply only slight pressure to the Chop Saw handle as it begins to cut through the workpiece. DO NOT apply too much pressure to the handle as this will cause the motor to slow down. Doing so will slow the cutting action and damage the motor.
 9. When the cut-off disc has completely cut through the workpiece, release the trigger switch immediately. Wait for the motor to come to a complete stop before lifting the cut-off disc away from the workpiece.

▲WARNING

Never touch the workpiece immediately after a cut is completed. The metal in the cutting area will be red hot and will cause severe burns to your skin.

MAINTENANCE

▲WARNING

When servicing, use only identical replacement parts. The use of any other part may create a hazard or cause product damage.

DO NOT use solvents when cleaning plastic parts. Plastics are susceptible to damage from various types of commercial solvents and may be damaged by their use. Use a clean cloth to remove dirt, dust, oil, grease, etc.

▲WARNING

DO NOT allow brake fluids, gasoline, petroleum-based products, penetrating oils, etc. to come into contact with plastic parts. They contain chemicals that can damage, weaken or destroy plastic.

Keep the air vents cleared of any built up dust to prevent the motor from overheating. Remove accumulated dust and debris regularly using a soft, DRY brush.

▲WARNING

Use safety goggles when using an air jet to blow dust out of the Chop Saw.

DO NOT abuse power tools. Abusive practices can damage the tool and the workpiece.

▲WARNING

DO NOT attempt to modify tools or create accessories. Any such alteration or modification is misuse and could result in a hazardous condition leading to possible serious injury. It will also void the warranty.

NOTE: It has been found that electric tools are subjected to accelerated wear and possible premature failure when they are used on fiberglass boats and sports cars, wallboard, spackling compounds or plaster. The chips and grindings from these materials are highly abrasive to electric tool parts such as bearings, brushes, commutators, etc. Consequently, it is not recommended that this tool be used for extended work on any fiberglass material, wallboard, spackling compounds or plaster. During any use on these materials, it is extremely important that the tool is cleaned frequently by blowing it out with an air jet.

LUBRICATION

All of the bearings in this tool are lubricated with a sufficient amount of high-grade lubricant for the life of the unit under normal conditions. Therefore, no further lubrication is required.



14" CHOP SAW

PARTS LIST

Figure	Description	Qty.
A	Hex Bolt	1
B	Small Clamp	1
C	Clamp	2
D	Cutting Wheel	1
E	Wrench	1
F	Rubber Foot	4
G	Base	1
H	Hex Nut	4
I	Vise Stand	1
J	Washer	5
K	Standard Spring Washer	3
L	Hex Bolt	2
M	Screw Assembly	1
N	Hatch Pin	2
O	Small Clamping Plate	1
P	Vise Column Pin	1
Q	Brush Cap Holder	2
R	Carbon Brush	2
S	Brush Holder	2
T	Rear Cover	1
U	Cross Screw	2
V	Cross Screw	2
W	Cross Screw	1
X	Standard Spring Washer	1
Y	Housing	1
Z	Stator	1
AA	Bearing	1
BB	Rotor	1
CC	Standard Spring Washer	6
DD	Cross Screw	2
EE	Switch	1
FF	Trigger	1
GG	Cross Screw	2
HH	Handle	1
II	Cross Screw	2
JJ	Cross Screw	1
KK	Cross Screw	2
LL	Left Handle	1
MM	Cross Screw	2
NN	Cord	1
OO	Cord Armor	1
PP	Cable Wire	1
QQ	Right Handle	1
RR	Hex Nut	3
SS	Handle	1

Figure	Description	Qty.
TT	Cross Screw	6
UU	Anti-Wind Ring	1
VV	Bearing	1
WW	Gear Box	1
XX	Protective Cover	1
YY	Cross Screw	4
ZZ	Active Cover	1
AAA	Screw	2
BBB	Spindle	1
CCC	Semi-Circle Key	1
DDD	Bearing	1
EEE	Spring Lock Pin	1
FFF	Lock Pin	1
GGG	Bearing Holder	1
HHH	Gear	1
III	Spring Washer	1
JJJ	Bearing	1
KKK	Circumgyrate Pin	1
LLL	Cross Screw	1
MMM	Washer	1
NNN	Standard Spring Washer	1
OOO	Dust Board	1
PPP	Big Spring	1
QQQ	Hex Nut	1
RRR	Hex Bolt	1
SSS	Pipe	1
TTT	Height Limited Pin	1
UUU	O-Ring	1
VVV	Limited Pin Cap	1
WWW	Hex Nut	1
XXX	Hex Screw	1
YYY	Hex Bolt	2
ZZZ	Standard Spring Washer	2
AAAA	Washer	2
BBBB	Scale Plate	1
CCCC	Column Spring Pin	1
DDDD	Speed Nut	1
EEEE	Fastener	3
FFFF	Hex Nut	2
GGGG	Cross Screw	3
HHHH	Cover Protector	1
IIII	Cross Screw	2
JJJJ	Column Cover Pin	1
KKKK	Washer	2
LLLL	Cross Screw	2



Intertek
3151837
J1G-HZ08-355

This symbol designates that this tool is listed with U.S. requirements by ETL Testing Laboratories, Inc. Conforms to UL STD No.987 Certified to CAN/CSA STD C22.2 No. 71.2.





14" CHOP SAW

PARTS DIAGRAM

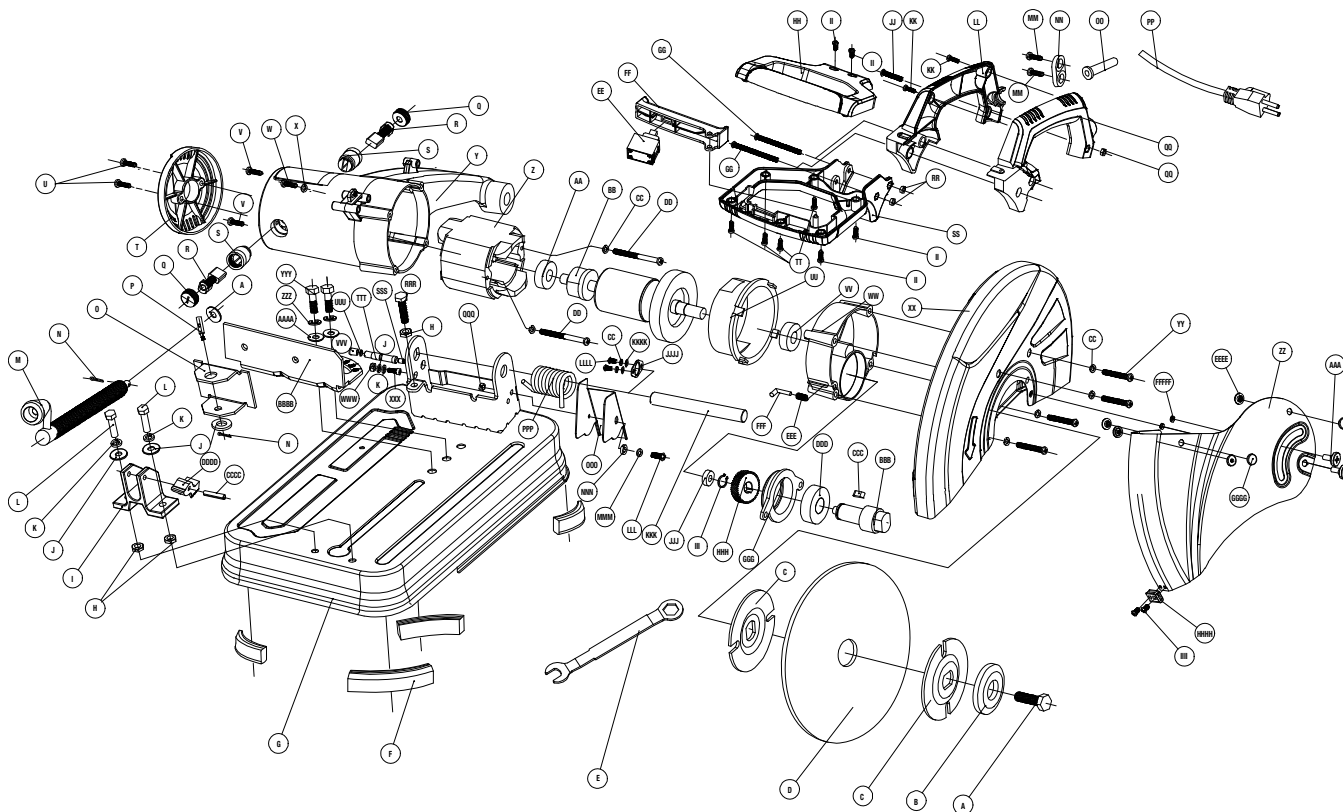

NOTE: Not all components of the product are replacement items but are illustrated as a convenient reference for location and position in the assembly sequence.

OEMTOOLS™ and/or its distributors have provided the parts list and assembly diagram as a reference only. Neither OEMTOOLS™ nor its distributors make any representation or warranty of any kind to the buyer and/or user of this tool that he or she is qualified to do any repairs or replace any parts of this product. OEMTOOLS™ and its distributors expressly state that all repairs or parts replacement should be done by certified or licensed technicians. The buyer assumes all risk and liability arising out of his or her repairs or parts replacement to the original production.



14" CHOP SAW

OEMTOOLS™ ONE YEAR WARRANTY

For up to one year from the date of purchase of this OEMTOOLS™ product, if you find any defect in material or workmanship (through normal usage), return it to the place of purchase or to OEMTOOLS™ for repair or replacement at our discretion. In order to obtain this service, send the product and proof of purchase (transportation pre-paid) to:

OEMTOOLS™ Q.A. Dept, 3580 E. Raines Road #3, Memphis, TN 38118.

We will not be responsible for lost or damaged goods during transportation; please insure your package. If our inspection verifies the defect, we will either repair or replace the product, or we may elect to refund the purchase price if we cannot readily and quickly provide you with a replacement. We will return repaired products at our expense, but if we determine there is no defect, or that the defect resulted from causes not within the scope of our warranty, then you must bear the cost of returning the product.

OEMTOOLS™ does not provide warranty for products labeled other than OEM® or OEMTOOLS™. OEMTOOLS™ will not provide any warranty for products subjected to abnormal use. Abnormal use includes (but is not limited to) abuse, accident, alteration, neglect, and unauthorized or unreasonable use or repairs. This warranty does not cover bits, blades, files, batteries, or calibration. We recommend that you maintain your tools and sharpen or replace blades, bits, files, and batteries as necessary. OEMTOOLS™ reserves the right to make any changes in construction or design at any time without any obligation in incorporating such changes to tools or equipment previously sold.

OEMTOOLS™ makes every effort to ensure that its products meet high quality and durability standards, and warrants to the original purchaser that this product is free from defects in materials and workmanship for the period of one year from the date of purchase. This warranty does not apply to damage due directly or indirectly to misuse, abuse, negligence or accidents, repairs or alterations outside our facilities, criminal activity, improper installation, normal wear and tear, or to lack of maintenance.

We shall in no event be liable for death, injuries to persons or property, or for incidental, contingent, special or consequential damages arising from the use of our product. Some states do not allow the exclusion or limitation of incidental or consequential damages, so the above limitation of exclusion may not apply to you. THIS WARRANTY IS EXPRESSLY IN LIEU OF ALL OTHER WARRANTIES, EXPRESS OR IMPLIED, INCLUDING THE WARRANTIES OF MERCHANTABILITY AND FITNESS. This warranty gives you specific legal rights, and you may also have other rights, which vary from state to state.

Don't forget to register your new OEMTOOLS™ product at www.oem-tools.com.

CONTACT US

3580 E. Raines Road, Suite 3, Memphis, TN 38118
Tel: 1-866-458-2472
www.oem-tools.com